

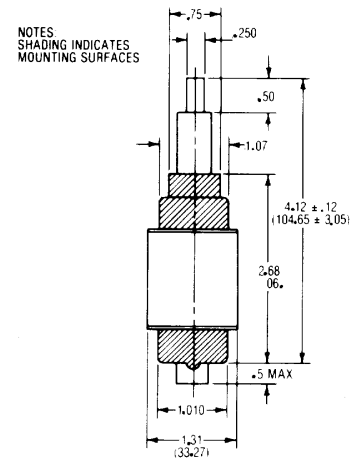

CADC 30 SPECIFICATIONS

Model Number	CADC-30-7.5S	CADC-30-10S	CADC-30-15S
Capacity Range (pF)	3-30	3-30	3-30
Voltage (kV) Peak			
Test	7.5	10	15
Working	4.5	6.0	9.0
Current Amps (RMS) Max.	18	19	20
Type	Ceramic	Ceramic	Ceramic
Nominal Dimensions			
Length (in. / mm)	4.62 / 117.34	4.62 / 117.34	4.62 / 117.34
Diameter (in. / mm)	1.30 / 33.27	1.30 / 33.27	1.30 / 33.27
Torque (in Lbs.) Max.	1.3†	1.3†	1.3†
Direct Pull (Lbs.) Max.	20	20	20
Weight (Nominal)	5 oz.	5 oz.	5 oz.
NOTES: <i>Mounting:</i> Use Jennings No. 112304 fuse clip, or soldered-on flange-types: CADC30-XXD1834 (flanges on both ends); CADC30-XXD1823 (fixed end flange only).			
† Adjustable			



CAPACITY vs TURNS
Typical Data

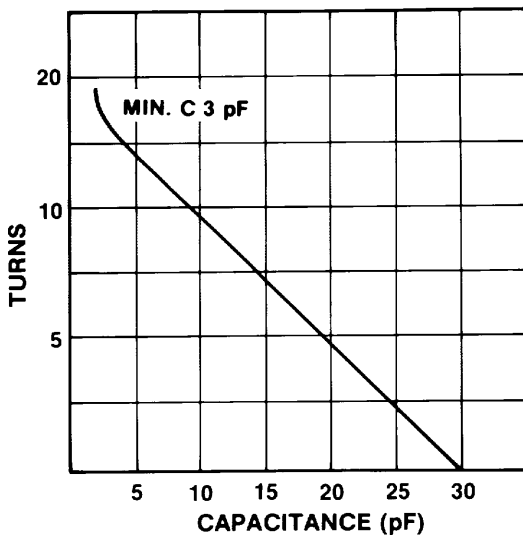

CONTINUOUS RMS AMPERES vs FREQUENCY
(at 9kV PEAK WORKING VOLTAGE)

